

SPECIFICATIONS

Cuzco Wall Mount Vanity

FRONT VIEW

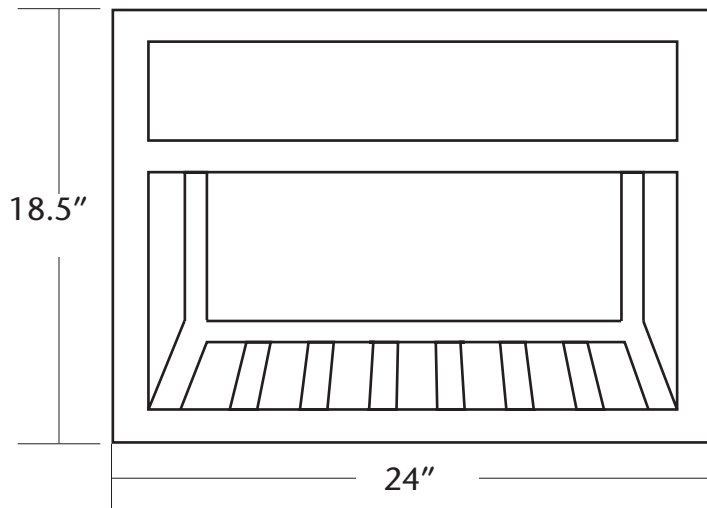

VNR192- Antique
VNR195- Brushed Nickel

PRODUCT DETAILS

- 24" w x 19" d x 18.5" h
- Hand forged iron with hand hammered, recycled copper accent panels
- Dimensions are not exact and may vary $\pm 1/2$ "

SIDE VIEW

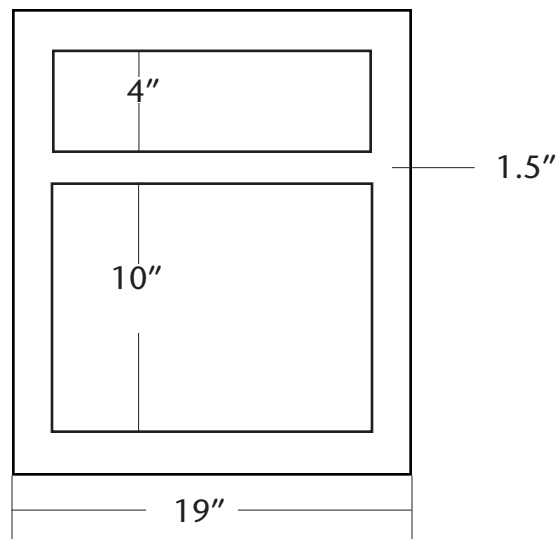

INSTALLATION

- Wall mount
- Combine with any Native Trails sink less than 15" OD front to back

COORDINATING PRODUCTS

- Sedona vanity top
- Any Native Trails stone vanity top
- Decorative Bottle Trap

IMPORTANT

Due to the handcrafted nature of this product, it will vary in finish, texture, hammering, and other details. Dimensions may vary up to $1/2$ ".