

SPECIFICATIONS

24" Cuzco Vanity

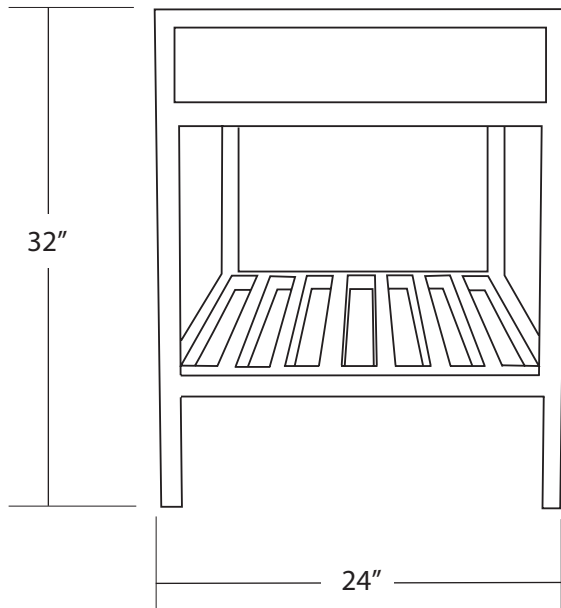

VNR242- Antique
VNR245- Brushed Nickel

PRODUCT DETAILS

- 24"w x 21.5"d x 32"h
- Wrought iron
- Hand hammered 16 gauge recycled copper
- Dimensions are not exact and may vary $\pm 1/2"$

INSTALLATION

- Freestanding vanity base

COORDINATING PRODUCTS

- Native Trails stone or Sedona vanity tops
- Decorative bottle trap

IMPORTANT

Due to the handcrafted nature of this product, it will vary in finish, texture, hammering, and other details. Dimensions may vary up to $1/2"$.

